



PERMIT TO OCCUPY THE PUBLIC RIGHT-OF-WAY

Permit # :	_____
Effective Date:	_____
Expiration Date:	_____
Non-Refundable Fee:	_____
Receipt # :	_____

**Sec. 16-121.(b) Work done without a permit.
The fee for failure to obtain a permit is four times the permit fee.**

REV. 01/2026

Applicant Information

Name (Print)	_____	Company:	_____
Address:	_____	E-mail:	_____
City,State, Zip:	_____	Telephone:	_____

Occupancy Information

General _____

Description/Reason: _____

Street Address: _____ Sidewalk/roadway obstruction requested Y or N

- or - Multiple Streets: _____

Dates (s) From: _____ To: _____ 35 days or < 35 days or >
(Requires Committee and Council Approval)

This permit approval is subject to the following conditions:

1. Permittee is responsible to obtain any further permits that may be required as part of this occupancy.
2. Permittee shall adhere to any plan(s) that were submitted to the City of Appleton as part of this application.
3. This permit is subject to IMMEDIATE REVOCATION and/or issuance of a MUNICIPAL CITATION if conditions of the permit are not met.
4. This permit is subject to IMMEDIATE REVOCATION if unfavorable traffic conditions develop during the period the occupancy is permitted.
5. Applicant is responsible for reimbursing City for electric usage charges. DPW may require adjustments to lighting fixtures, output, and/or positioning after initial implementation
- 6.

This permit is issued to the applicant upon payment of the permit fee and is expressly limited to the location and type described herein. The applicant, in exchange for receiving this permit, warrants that all street occupancies will be performed in conformity to City ordinances, standards and policies, be properly barricaded and lighted, and be performed in a safe manner. By applying for and accepting this permit, the applicant assumes full liability and/or any costs incurred by the City for corrective work required to bring the subject area into compliance with said ordinances, standards, policies and permit conditions. No occupancy shall occur prior to approval of this permit by the Department of Public Works. The Grantee shall guarantee at their expense, the repair or replacement of pavement, sidewalk and any other facilities within the public right-of-way damaged or destroyed by the Grantee or any sub-contractor working for them. The Grantee shall assume complete and full liability and responsibility, in accordance with existing ordinances and policies, in the event of injury or damage to persons or property resulting from their facilities within the public right-of-way.

SIGNED BY: _____
(Applicant)

DATE: _____

(Department use only)

<u>Occupancy Type</u>	<u>Sub-Type</u>	<u>Location</u>
<input type="checkbox"/> Permanent - Obstruction (\$40)	<input type="checkbox"/> Awning	<input type="checkbox"/> Sandwich Board
<input type="checkbox"/> Temporary - Obstruction (\$40)	<input type="checkbox"/> Dumpster	<input type="checkbox"/> Tables/Chairs
<input type="checkbox"/> Amenity/Annual (\$40)	<input type="checkbox"/> Sign	<input type="checkbox"/> Sidewalk
<input type="checkbox"/> Blanket/Annual (\$250)	<input type="checkbox"/> Obstruction / Other	<input type="checkbox"/> Terrace
<input type="checkbox"/> Block Party (\$15)	<input type="checkbox"/> POD / Container	<input type="checkbox"/> Roadway

Additional Requirements

Construction Plan/Sketch Certificate of Insurance Bond Committee and Council Approval

Other: _____ Date: _____

Work Zone Traffic Control Requirements

Contact Traffic Division at 920-832-2304 or traffic.engineering@appletonwi.gov 1 business day prior to any lane closure, or 2 business days prior to a full road closure.

<u>Type of Street:</u>	<u>Proposed Traffic Control:</u>
<input type="checkbox"/> Arterial/CBD	<input type="checkbox"/> City Manual Page(s) _____
<input type="checkbox"/> Collector	<input type="checkbox"/> State Manual Page(s) _____
<input type="checkbox"/> Local	<input type="checkbox"/> Other (attach plan) _____

Additional Requirements: _____

Approved by: _____ **Date:** _____

APPROVED BY: _____
(Department of Public Works)

DATE: _____

College Ave Tree Light Proposal

From: Creative Downtown Appleton Inc

• Brief description of the proposed project

To install lighting to illuminate the boulevard trees on College Ave. between Badger/Story and Drew Street

• Photos/sketches of proposed work:

Sketch attached

• Site plan/location map showing location of proposed work

97 Total planters between Badger/Story and Drew Street on College Ave sidewalks ... 32 Big and 65 Small

IF costs exceed \$45,000 - we will scale back the number of tree lights to every other planter or only the large planters.

• Reason for choosing the proposed location:

Pedestrian lighting can enhance public safety and economic vitality. By illuminating sidewalks at a human scale it creates a higher level of comfort and deters crime. This sense of comfort encourages "foot traffic," inviting residents and tourists to linger longer, which directly boosts revenue for local restaurants and retailers. Beyond utility, pedestrian lighting offers "placemaking" value, creating a warm, inviting atmosphere that fosters social interaction and reinforces the downtown's identity as a walkable, community center.

• Description of how the work is installed/anchored/attached

Installation details:

- Hard wire installation completed by Bissing Electric team.
- Arlington 19" Gard-n-Post GPLN19B – attached details
- Light product WAC line-voltage floodlights wired to existing GFCI receptacles – Details attached
- ½" non-metallic flexible conduit w/12-2 UF Cable & steel fittings
- Installation will be within the planters on the street side aimed away from traffic to up light the tree toward the buildings. We will be sensitive to light spill to any living quarters.
- Drawing or schematic that details placement, orientation, materials, and parts shall be provided for review. – attached

• Timeline and duration of installation

We will begin installation once our approval with the City of Appleton is complete. Our goal is to have installation complete by July 29 in time for Mile of Music.

• How the lights will be maintained

- CDA will retain a maintenance budget to replace or repair any damaged lights, posts or conduit or wiring up to the outlet box.
- City input needed here: Criteria for quality of operation (what triggers maintenance and/or removal) will need to be established. Maintenance, beyond the original planter outlet, provided through CDA

• Description of any associated signage

Seeking to install a sign to acknowledge our donor. Sized to fit on the Gard-n-post. Made of plastic with vinyl lettering: Light the Ave by Gary and Alicia Schmitz

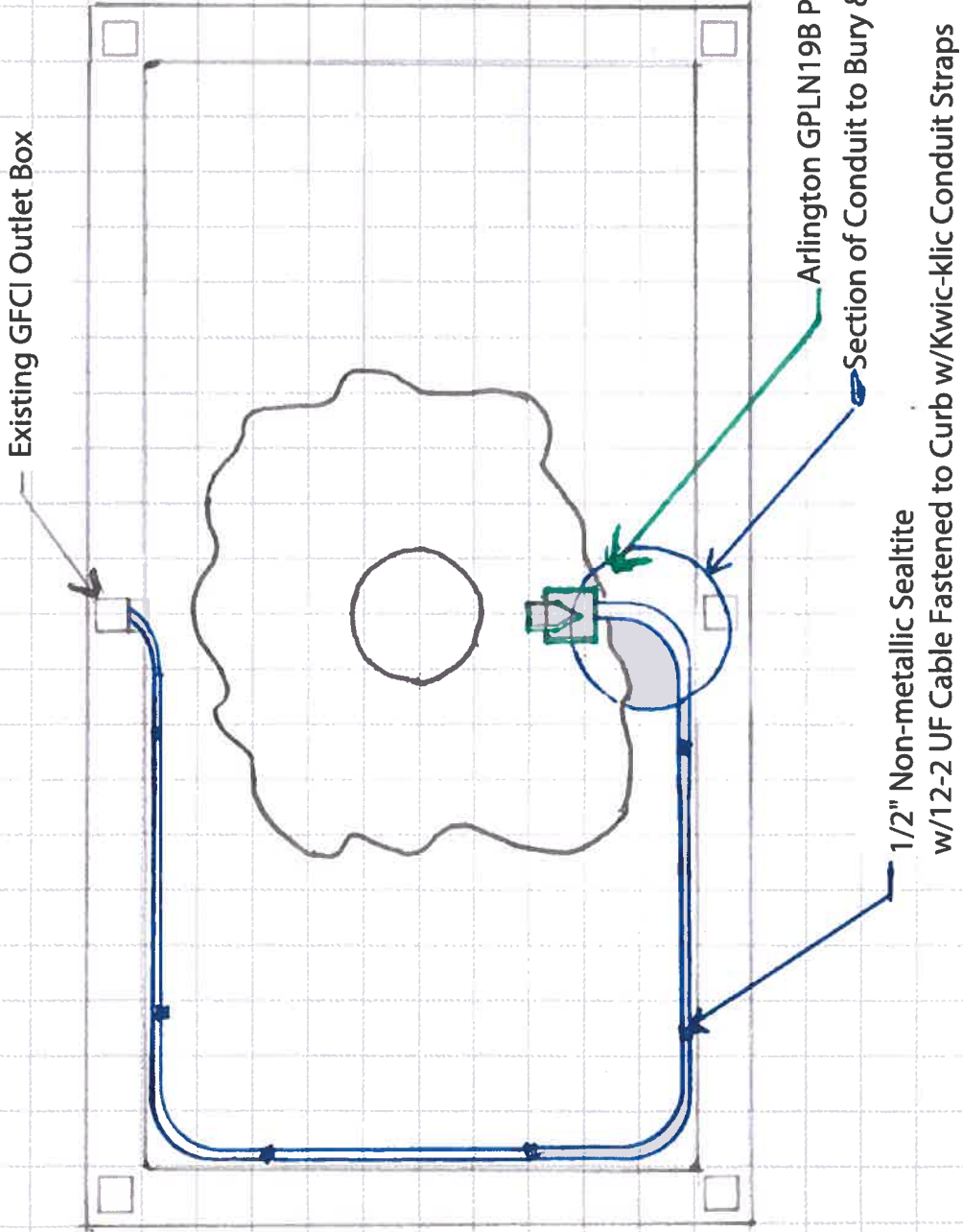

Existing GFCI Outlet Box

Arlington GPLN19B Post w/WAC Floodlight (120V)

Section of Conduit to Bury & Enter Post from Bottom

1/2" Non-metallic Sealite
w/12-2 UF Cable Fastened to Curb w/Kwic-klic Conduit Straps

Section of Conduit to Bury & Enter Post from Bottom

GARD-N-POST™ Low Profile Support

JUST FOR 2- AND 3-WIRE LIGHT FIXTURES • LOW COST

GPLN19 19.5"

GPL19 19.5"

GPLN15GR 15"

Installing a 2- or 3-wire outdoor light fixture is easier, and less expensive with Arlington's low cost Gard-N-Posts.

The GPLN series low profile support is designed for 3-wire light fixtures. It comes with a 3/4" NPT threaded opening, and an installed 3/4 x 1/2 non-metallic reducing bushing for use with 1/2" or 3/4" NPT fixtures.

- Installed cover
- Permanent colors – No chipping
- Heavy-duty – Resists damage from lawn mowers and other lawn maintenance equipment
- UV rated plastic for long outdoor life
- UL and CSA Listed

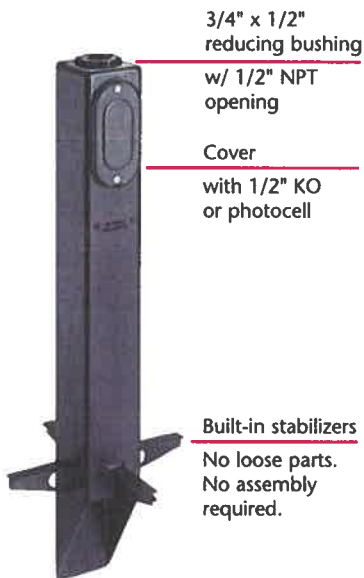

3/4" x 1/2" reducing bushing w/ 1/2" NPT opening

Cover with 1/2" KO or photocell

Built-in stabilizers
No loose parts. No assembly required.

GPLN19
Non-metallic bushing for 3-wire fixtures only

Our Absolutely LOWEST COST Gard-N-Post



GPLN15GR
Non-metallic bushing for 3-wire fixtures only

GPL19
Metal bushing with ground wire for 2- or 3-wire fixtures



GPLN19 19.5" Height • Non-Metallic Bushing

CATALOG NUMBER	UPC/DCI/NAED MFG. #01 8997	COLOR	UNIT PKG	STD PKG
GPLN19B	76190	Black	6	6
GPLN19BR	76192	Bronze	6	6

GPLN19 & GPLN15GR Include: Access panel cover, gasket, 3/4" x 1/2" NPT non-metallic bushing for fixture installation.

GPLN15GR 15" Height • Non-Metallic Bushing

GPLN15GR	76181	Gray	10	
----------	-------	------	----	--

Note for all: Add suffix 'GC' for orders in Canada

GPL19 19.5" Height • Metal Bushing

CATALOG NUMBER	UPC/DCI/NAED MFG. #01 8997	COLOR	UNIT PKG	STD PKG
GPL19B	77000	Black	1	6
GPL19BR	77001	Bronze	1	6
GPL19G	77002	Green	1	6
GPL19W	77003	White	1	6

Includes: Access panel cover, gasket, installed 3/4" x 1/2" NPT metal grounding bushing and locknut with copper ground wire for fixture installation.

ACCENT 120V

5012

WAC

LANDSCAPE LIGHTING

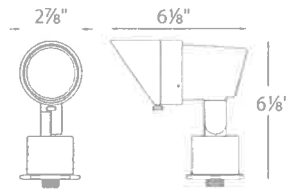

Fixture Type:

Catalog Number:

Project: _____

Location: _____

PRODUCT DESCRIPTION

Landscape accent luminaire. Simple to retrofit existing line voltage systems or coordinate well with a new commercial landscape installation.

FEATURES

- Adjustable and lockable beam angle
- Integral dimmer
- IP66 rated, Protected against high-pressure water jets
- Includes a detachable shroud
- Solid diecast brass or corrosion resistant aluminum
- Factory sealed water tight fixtures
- Detachable shroud, 6' lead wire and wire nuts included
- Maintains constant lumen output against voltage drop
- UL 1598 Listed
- Not suitable to use with external dimmers
- Integrated LED

SPECIFICATIONS

Input: 110V - 120VAC
Power: 3.5W to 14.5W (Use VA value for sizing the transformer and calculate voltage drop.)
Brightness: 100 lm to 900 lm
Beam Angle: 15° to 60°
CRI: 85
Rated Life: 45,000 hours

ORDERING NUMBER

		Color Temp	Finish
5012	<i>Accent 120V</i>	30 3000K	BK <i>Black on Aluminum</i>
			BZ <i>Bronze on Aluminum</i>
			BBR <i>Bronze on Brass</i>

5012-30_____

Example: **5012-30BBR**

wacighting.com
 Phone (800) 526.2588
 Fax (800) 526.2585

Headquarters, East Manufacturing Facility
 44 Harbor Park Drive
 Port Washington, NY 11050

South East Manufacturing Facility
 1600 Distribution Ct
 Lithia Springs, GA 30122

Central Manufacturing Facility
 1700 South J Elmer Freeway, Ste 100
 Cedar Hill, TX 75104

West Manufacturing Facility
 1750 S Archibald Ave
 Ontario, CA 91761









ACCENT 120V

5012

WAC

LANDSCAPE LIGHTING

Accessories

Power Stake		M6000-STAKE	PVC		Easy wiring accessory designed for 12V & 120V products Eliminates the need for a separate Junction box
Accent Snoot		5010-SNOOT-BK 5010-SNOOT-BZ 5010-SNOOT-BBR	Black on Aluminum Bronze on Aluminum Bronze on Brass		Shields lamp and reduces glare
6" Long Shroud		5010-LSHR-BK 5010-LSHR-BZ 5010-LSHR-BBR	Black on Aluminum Bronze on Aluminum Bronze on Brass		Reduce glare. Ideal for downlighting application
Gutter Mount Bracket		5000-GM-BZ 5000-GM-BK	Stainless Steel		Stainless Steel universal mounting bracket for gutter mounting fixture
Tree Mount Junction Box		5000-TCP-BZ 5000-TCP-BK	Bronze on Aluminum Black on Aluminum		Bronze on Aluminum box with Stainless steel mounting screws. Two 1/2" NPT threaded holes
Optics		LENS-20-AMB LENS-20-GRN LENS-20-RED	Amber Green Red	LENS-20-BLU LENS-20-FR LENS-20-SPR	Blue Frosted Spread Enhances saturation of florals and foliage
Extension Rods		5000-X04-BZ 5000-X04-BK 5000-X08-BZ 5000-X08-BK 5000-X12-BZ 5000-X12-BK	4 in 4 in 8 in 8 in 12 in 12 in	5000-X18-BZ 5000-X18-BK 5000-X24-BZ 5000-X24-BK	18 in 18 in 24 in 24 in Extends distance between Accent light and Surface Mount Canopy, Stake, or Tree Mount box
Rod L-Coupler		5000-LCO-BZ	Bronze		

wacighting.com
Phone (800) 526.2588
Fax (800) 526.2585

Headquarters, East Manufacturing Facility
44 Harbor Park Drive
Port Washington, NY 11050

South East Manufacturing Facility
1600 Distribution Ct
Lithia Springs, GA 30122

Central Manufacturing Facility
1700 South J Elmer Freeway, Ste 100
Cedar Hill, TX 75104

West Manufacturing Facility
1750 S Archibald Ave
Ontario, CA 91761

INSTALLATION INSTRUCTION

Accent

5012

WAC
LANDSCAPE LIGHTING

WARNING

IMPORTANT: NEVER attempt to do any work without shutting off the electricity.

1. Read all instructions before installing.
2. System is intended for installation by a qualified electrician in accordance with the National Electrical Code and local regulations.
3. Place the wall switch in the "OFF" position.
4. Go to the main fuse box, or circuit breaker. Unscrew the fuse(s) or switch "OFF" the circuit breaker switch(es) that control the power to the space that you are working on.

CAUTION

- All parts must be used as indicated in these instructions. Do not substitute any parts, leave parts out, or use any parts that are worn out or broken. Failure to follow this instruction may invalidate the UL listing of this fixture.

AVERTISSEMENT

IMPORTANT : Coupez l'électricité avant TOUTE manipulation.

- Lisez toutes les instructions avant d'installer.
- Système est destiné à être installé par un électricien qualifié en conformité avec le code national de l'électricité et les règlements locaux.
- Placez l'interrupteur mural en position d'arrêt (« OFF »).
- Toujours mettre le fusible ou le disjoncteur en position arrêt dans la pièce ou des travaux électriques sont prévus

MISE EN GARDE

- Toutes les pièces doivent être utilisées tel qu'il est indiqué dans ces instructions. Ne remplacez pas les pièces, n'en laissez pas de côté et ne les utilisez pas si elles sont usées ou brisées. Le non-respect de ces instructions peut annuler l'homologation UL du luminaire.

ADVERTENCIA

IMPORTANTE: NUNCA intente hacer trabajos sin desconectar el suministro eléctrico.

- Lea y comprenda todas las instrucciones e ilustraciones por completo antes de proceder con el ensamblaje e instalación de esta lámpara.
- Sistema está diseñado para ser instalado por un electricista calificado, de acuerdo con el código eléctrico nacional y las normas locales.
- Coloque el interruptor de la pared en la posición "OFF" (APAGADO).
- Diríjase a la caja de fusibles o a la caja del interruptor de circuito principal en su hogar. Coloque el interruptor de alimentación principal en la posición "OFF" (APAGADO).

PRECAUCIÓN

- Todas las piezas deben usarse como lo indican estas instrucciones. No reemplace las piezas, noomita piezas durante la instalación ni utilice piezas gastadas o rotas. El incumplimiento de esta indicación podría invalidar la calificación UL esta lámpara.

This instruction apply to the model(s) below:

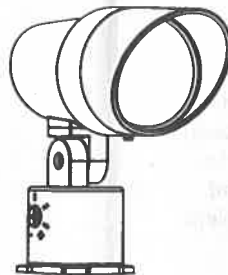

5012-30

waclighting.com
Phone (800) 526.2588
Fax (800) 526.2585

Headquarters/Eastern Distribution Center
44 Harbor Park Drive
Port Washington, NY 11050

Central Distribution Center
1600 Distribution Ct
Lithia Springs, GA 30122

Western Distribution Center
1750 Archibald Avenue
Ontario, CA 91760

MOUNTING ACCESSORIES

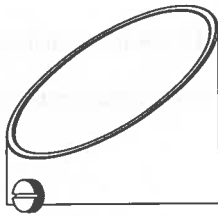

Adjustable Shroud
Qty: 1pc



Rated Wire Nut
Qty: 3pcs

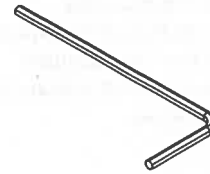

Hex Key
Qty: 1pcs

Step 1: Installing the fixture on Power Stake

1. Make sure your main power is off.
2. Excavate a trench for the UF supply line cable or conduit/conductors and the Landscape Power Stake. The Landscape Power Stake requires approximately a one (1) square foot hole to facilitate installation. The excavated should be approximately 15" deep. This will allow the hex-head set screw on the Power Stake to remain above ground when the installation is completed.
3. Turn the hex-head set screw counterclockwise to remove the Power Stake Cap from the top of the PVC Light Stake.
4. Feed the light fixtures black, white, and ground wires through the top of the Power Stake Cap. Then, thread the light fixture until it's firmly attached to the Power Stake Cap.
5. Fed the incoming supply line cable through the slanted bottom of the PVC Light Stake. Note: If you are wiring multiple light fixtures in series, also bring the second supply line cable into the PVC Light Stake.
6. Bring the supply line cable through knockout hole in the Separator Disk. If second supply line is required, carefully break-out and remove the second knockout in the Separator Disk.
7. Attached a UF connector(s) to supply line cable(s), then secure the connector(s) to the Separator Disk.
8. Using appropriate UL Listed wire connectors, splice the white wire from the light fixture to the incoming supply line cable(s) white wire(s), and the black wire from the light fixture to the incoming supply line's black wire(s). Then splice the ground wire from the light fixture to the incoming supply line cable(s) ground wire(s).

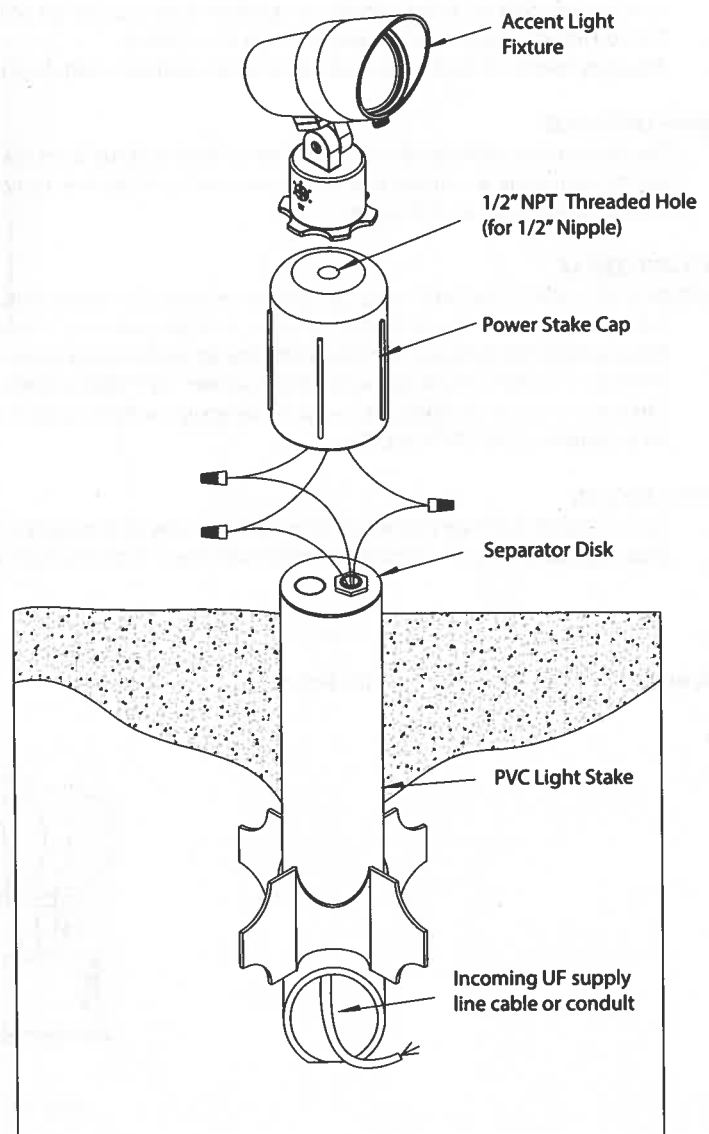

waclighting.com
Phone (800) 526.2588
Fax (800) 526.2585

Headquarters/Eastern Distribution Center
44 Harbor Park Drive
Port Washington, NY 11050

Central Distribution Center
1600 Distribution Ct
Lithia Springs, GA 30122

Western Distribution Center
1750 Archibald Avenue
Ontario, CA 91760

9. Place the Separator Disk squarely on top of the PVC Light Stake. Then place the Power Stake Cap with attached light fixture over the PVC Light Stake and Separator Disk. Carefully push the incoming supply line cable down into the PVC Light Stake. Tighten the hex-head screw clockwise on the Landscape Power Stake Cap.
10. Lower the completely wired and assembled Landscape Power Stake into the excavated hole. Make sure that the excavated hole is approximately 15" deep to allow the hex-head set screw on the Landscape Power Stake Cap to remain above the ground.
11. Back fill the soil around the Landscape Power Stake.
12. Screw the fixture onto the stake provided, leading the wire from the fixture through the wire slot in the stake.
13. If desired, bury your wire by digging a small trench. Close the trench by applying an inward force to both sides of the trench.
14. Repeat steps for other fixtures in the same electrical circuit.
15. Turn the main power supply back on and make sure the fixtures light up.

Step 4: Aiming the Fixture

16. Tilting: Loosen the joint screw and adjust the head of the fixture to the desired direction before retightening the screw.
17. Rotating: Loosen the mounting knob and rotate the fixture to the desired position before retightening the knob.

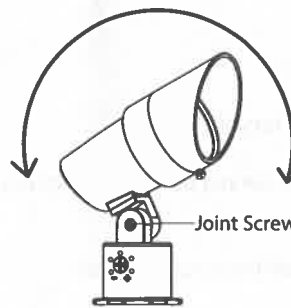

Tilting

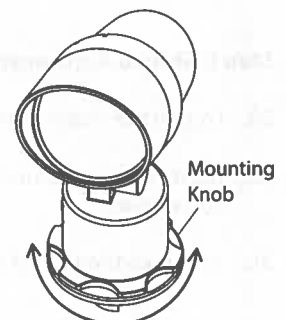

Rotating

waclighting.com
Phone (800) 526.2588
Fax (800) 526.2585

Headquarters/Eastern Distribution Center
44 Harbor Park Drive
Port Washington, NY 11050

Central Distribution Center
1600 Distribution Ct
Lithia Springs, GA 30122

Western Distribution Center
1750 Archibald Avenue
Ontario, CA 91760

Step 3: Dimming Adjustment:

18. Use a Phillips head screwdriver to adjust the dimming dial.
19. Rotate until the arrow on the dial is pointed at the desired wattage. The wattage may be adjusted to the pre-existing tabs or any value in between.
20. The lower the wattage, the dimmer the fixture will be.
21. Please refer to the yellow tag to determine the size of the required transformer.

Step 4: Beam Angle Adjustment:

22. Note the four pre-determined beam angles on the beam angle changing dial.
23. Remove shroud before adjusting beam angle (See step 7)
24. Use the provided Hex Key to slightly loosen the set screw one or two turns. Do not remove set screw from the fixture.

CAUTION: Do not remove set screw from the fixture. It should only be removed from the fixture for servicing. Consult factory for service instruction.

25. Hold the fixture body and Rotate the dial until the arrow is aligned with the desired beam angle. This beam angle may be one of the pre-determined markings or any number in between.

CAUTION: Keep the arrow marking on the fixture body between the beam angle range.

26. Tighten the set screw until it stops. Do not over tighten.
27. Install the shroud

Step 5: Shroud Adjustment

28. Loosen the thumb screw on the shroud.
29. Rotate the shroud until it is in the desired position to properly cut off glare.
30. Retighten the thumb screw to lock the shroud in place.

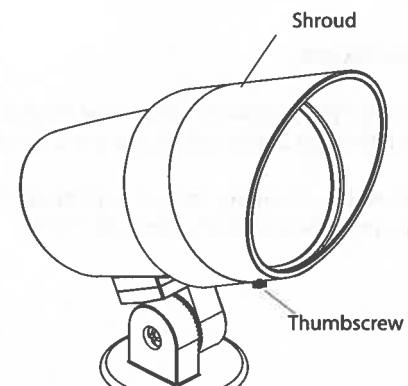
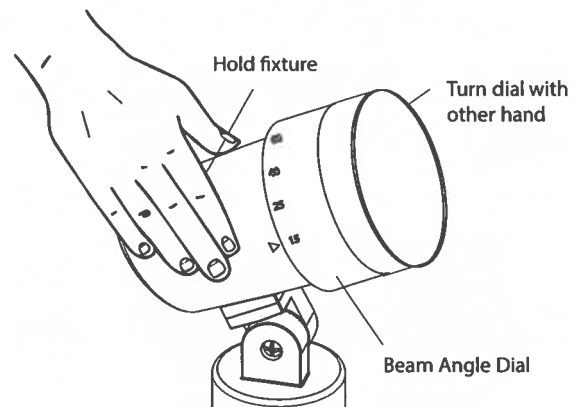
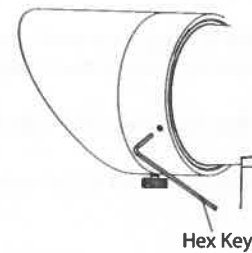
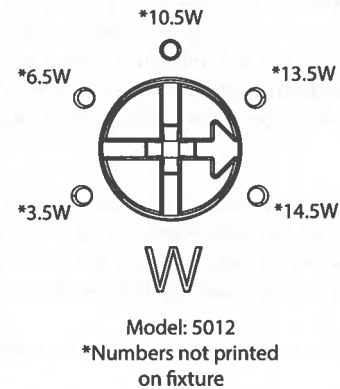

wacighting.com
Phone (800) 526.2588
Fax (800) 526.2585

Headquarters/Eastern Distribution Center
44 Harbor Park Drive
Port Washington, NY 11050

Central Distribution Center
1600 Distribution Ct
Lithia Springs, GA 30122

Western Distribution Center
1750 Archibald Avenue
Ontario, CA 91760

		Fixture Yearly Cost			
Wattage	Lumen	3 Hr/\$.15 kWh	5 Hr/\$.15 kWh	7 Hr/\$.15 kWh	
3.5	100	\$ 0.58	\$ 0.96	\$ 1.34	
6.5	220	\$ 1.07	\$ 1.78	\$ 2.49	
10.5	425	\$ 1.73	\$ 2.88	\$ 4.03	
13.5	680	\$ 2.22	\$ 3.70	\$ 5.18	
14.5	795	\$ 2.38	\$ 3.97	\$ 5.56	
Wattage	Lumen	3 Hr/\$.175 kWh	5 Hr/\$.175 kWh	7 Hr/\$.175 kWh	
3.5	100	\$ 0.67	\$ 1.12	\$ 1.57	
6.5	220	\$ 1.25	\$ 2.08	\$ 2.91	
10.5	425	\$ 2.01	\$ 3.36	\$ 4.70	
13.5	680	\$ 2.59	\$ 4.31	\$ 6.04	
14.5	795	\$ 2.78	\$ 4.63	\$ 6.49	
Wattage	Lumen	3 Hr/\$.20 kWh	5 Hr/\$.20 kWh	7 Hr/\$.20 kWh	
3.5	100	\$ 0.77	\$ 1.28	\$ 1.79	
6.5	220	\$ 1.42	\$ 2.37	\$ 3.32	
10.5	425	\$ 2.30	\$ 3.84	\$ 5.37	
13.5	680	\$ 2.96	\$ 4.93	\$ 6.90	
14.5	795	\$ 3.62	\$ 6.03	\$ 8.44	
96 Fixture Yearly Cost					
Wattage	Lumen	3 Hr/\$.15 kWh	5 Hr/\$.15 kWh	7 Hr/\$.15 kWh	
3.5	100	\$ 55.68	\$ 92.16	\$ 128.64	
6.5	220	\$ 102.72	\$ 170.88	\$ 239.04	
10.5	425	\$ 166.08	\$ 276.48	\$ 386.88	
13.5	680	\$ 213.12	\$ 355.20	\$ 497.28	
14.5	795	\$ 228.48	\$ 381.12	\$ 533.76	
Wattage	Lumen	3 Hr/\$.175 kWh	5 Hr/\$.175 kWh	7 Hr/\$.175 kWh	
3.5	100	\$ 64.32	\$ 107.52	\$ 150.72	
6.5	220	\$ 120.00	\$ 199.68	\$ 279.36	
10.5	425	\$ 192.96	\$ 322.56	\$ 451.20	
13.5	680	\$ 248.64	\$ 413.76	\$ 579.84	
14.5	795	\$ 266.88	\$ 444.48	\$ 623.04	
Wattage	Lumen	3 Hr/\$.20 kWh	5 Hr/\$.20 kWh	7 Hr/\$.20 kWh	
3.5	100	\$ 73.92	\$ 122.88	\$ 171.84	
6.5	220	\$ 136.32	\$ 227.52	\$ 318.72	
10.5	425	\$ 220.80	\$ 368.64	\$ 515.52	
13.5	680	\$ 284.16	\$ 473.28	\$ 662.40	
14.5	795	\$ 347.52	\$ 578.88	\$ 810.24	



CERTIFICATE OF LIABILITY INSURANCE

DATE (MM/DD/YYYY)

03/17/2026

THIS CERTIFICATE IS ISSUED AS A MATTER OF INFORMATION ONLY AND CONFERS NO RIGHTS UPON THE CERTIFICATE HOLDER. THIS CERTIFICATE DOES NOT AFFIRMATIVELY OR NEGATIVELY AMEND, EXTEND OR ALTER THE COVERAGE AFFORDED BY THE POLICIES BELOW. THIS CERTIFICATE OF INSURANCE DOES NOT CONSTITUTE A CONTRACT BETWEEN THE ISSUING INSURER(S), AUTHORIZED REPRESENTATIVE OR PRODUCER, AND THE CERTIFICATE HOLDER.

IMPORTANT: If the certificate holder is an ADDITIONAL INSURED, the policy(ies) must have ADDITIONAL INSURED provisions or be endorsed. If SUBROGATION IS WAIVED, subject to the terms and conditions of the policy, certain policies may require an endorsement. A statement on this certificate does not confer rights to the certificate holder in lieu of such endorsement(s).

PRODUCER Truyma Haase Zahn Insurance Group 114 S Main St PO Box 6 Seymour, WI 54165	CONTACT NAME: PHONE (A/C No. Ext): (920) 833-6871 FAX (A/C, No): (920) 833-6870 E-MAIL ADDRESS: info@thzins.com	
	INSURER(S) AFFORDING COVERAGE	
INSURED Appleton Downtown Inc PO Box 2272 Appleton, WI 54912	INSURER A: Secura Insurance NAIC # 22543	
	INSURER B: The Hartford HARTF1	
	INSURER C:	
	INSURER D:	
	INSURER E:	
	INSURER F:	

COVERAGES**CERTIFICATE NUMBER:****REVISION NUMBER:**

THIS IS TO CERTIFY THAT THE POLICIES OF INSURANCE LISTED BELOW HAVE BEEN ISSUED TO THE INSURED NAMED ABOVE FOR THE POLICY PERIOD INDICATED. NOTWITHSTANDING ANY REQUIREMENT, TERM OR CONDITION OF ANY CONTRACT OR OTHER DOCUMENT WITH RESPECT TO WHICH THIS CERTIFICATE MAY BE ISSUED OR MAY PERTAIN, THE INSURANCE AFFORDED BY THE POLICIES DESCRIBED HEREIN IS SUBJECT TO ALL THE TERMS, EXCLUSIONS AND CONDITIONS OF SUCH POLICIES. LIMITS SHOWN MAY HAVE BEEN REDUCED BY PAID CLAIMS.

INSR LTR	TYPE OF INSURANCE	ADDL INSD	SUBR WVD	POLICY NUMBER	POLICY EFF (MM/DD/YYYY)	POLICY EXP (MM/DD/YYYY)	LIMITS
A	<input checked="" type="checkbox"/> COMMERCIAL GENERAL LIABILITY <input type="checkbox"/> CLAIMS-MADE <input checked="" type="checkbox"/> OCCUR GEN'L AGGREGATE LIMIT APPLIES PER: <input checked="" type="checkbox"/> POLICY <input type="checkbox"/> PRO-JECT <input type="checkbox"/> LOC OTHER:	Y		CP3301626	04/15/2026	04/15/2027	EACH OCCURRENCE \$ 1,000,000 DAMAGE TO RENTED PREMISES (Ea occurrence) \$ 500,000 MED EXP (Any one person) \$ 10,000 PERSONAL & ADV INJURY \$ 1,000,000 GENERAL AGGREGATE \$ 2,000,000 PRODUCTS - COMP/OP AGG \$ 2,000,000
	AUTOMOBILE LIABILITY <input type="checkbox"/> ANY AUTO <input type="checkbox"/> OWNED AUTOS ONLY <input type="checkbox"/> SCHEDULED AUTOS <input type="checkbox"/> HIRED AUTOS ONLY <input type="checkbox"/> NON-OWNED AUTOS ONLY						COMBINED SINGLE LIMIT (Ea accident) \$ BODILY INJURY (Per person) \$ BODILY INJURY (Per accident) \$ PROPERTY DAMAGE (Per accident) \$
A	<input checked="" type="checkbox"/> UMBRELLA LIAB <input type="checkbox"/> OCCUR <input type="checkbox"/> EXCESS LIAB <input type="checkbox"/> CLAIMS-MADE <input type="checkbox"/> DED <input checked="" type="checkbox"/> RETENTION \$ 10000			CU3301635	04/15/2026	04/15/2027	EACH OCCURRENCE \$ 1,000,000 AGGREGATE \$ 1,000,000
B	WORKERS COMPENSATION AND EMPLOYERS' LIABILITY ANY PROPRIETOR/PARTNER/EXECUTIVE OFFICER/MEMBER EXCLUDED? (Mandatory in NH) If yes, describe under DESCRIPTION OF OPERATIONS below	Y/N	N/A	83WECAC9T18	04/15/2026	04/15/2027	<input checked="" type="checkbox"/> PER STATUTE <input type="checkbox"/> OTHER E.L. EACH ACCIDENT \$ 100,000 E.L. DISEASE - EA EMPLOYEE \$ 100,000 E.L. DISEASE - POLICY LIMIT \$ 500,000
A	Directors & Officers Liability			CP3301626	4/15/2026	4/15/2027	Per Occurrence \$1,000,000
A	Liquor Liability			CP3301626	4/15/2026	4/15/2027	Per Occurrence \$1,000,000

DESCRIPTION OF OPERATIONS / LOCATIONS / VEHICLES (ACORD 101, Additional Remarks Schedule, may be attached if more space is required)

Parklet - 201 N APPLETON ST,

City of Appleton as additional insured - when required by contract per form CGT1000
 Commercial Umbrella follows forms of underlying policies.

CERTIFICATE HOLDER**CANCELLATION**

City Of Appleton 100 N. Appleton Street Appleton, WI 54911	SHOULD ANY OF THE ABOVE DESCRIBED POLICIES BE CANCELLED BEFORE THE EXPIRATION DATE THEREOF, NOTICE WILL BE DELIVERED IN ACCORDANCE WITH THE POLICY PROVISIONS. AUTHORIZED REPRESENTATIVE 
--	--

© 1988-2015 ACORD CORPORATION. All rights reserved.



CERTIFICATE OF LIABILITY INSURANCE

DATE (MM/DD/YYYY)

03/17/2026

THIS CERTIFICATE IS ISSUED AS A MATTER OF INFORMATION ONLY AND CONFERS NO RIGHTS UPON THE CERTIFICATE HOLDER. THIS CERTIFICATE DOES NOT AFFIRMATIVELY OR NEGATIVELY AMEND, EXTEND OR ALTER THE COVERAGE AFFORDED BY THE POLICIES BELOW. THIS CERTIFICATE OF INSURANCE DOES NOT CONSTITUTE A CONTRACT BETWEEN THE ISSUING INSURER(S), AUTHORIZED REPRESENTATIVE OR PRODUCER, AND THE CERTIFICATE HOLDER.

IMPORTANT: If the certificate holder is an ADDITIONAL INSURED, the policy(ies) must have ADDITIONAL INSURED provisions or be endorsed. If SUBROGATION IS WAIVED, subject to the terms and conditions of the policy, certain policies may require an endorsement. A statement on this certificate does not confer rights to the certificate holder in lieu of such endorsement(s).

PRODUCER Truyma Haase Zahn Insurance Group 114 S Main St PO Box 6 Seymour, WI 54165	CONTACT NAME: PHONE (A/C No. Ext): (920) 833-6871 FAX (A/C, No): (920) 833-6870 E-MAIL ADDRESS: info@thzins.com	
	INSURER(S) AFFORDING COVERAGE	
INSURED Appleton Downtown Inc PO Box 2272 Appleton, WI 54912	INSURER A: Secura Insurance NAIC # 22543	
	INSURER B: The Hartford HARTF1	
	INSURER C:	
	INSURER D:	
	INSURER E:	
	INSURER F:	

COVERAGES**CERTIFICATE NUMBER:****REVISION NUMBER:**

THIS IS TO CERTIFY THAT THE POLICIES OF INSURANCE LISTED BELOW HAVE BEEN ISSUED TO THE INSURED NAMED ABOVE FOR THE POLICY PERIOD INDICATED. NOTWITHSTANDING ANY REQUIREMENT, TERM OR CONDITION OF ANY CONTRACT OR OTHER DOCUMENT WITH RESPECT TO WHICH THIS CERTIFICATE MAY BE ISSUED OR MAY PERTAIN, THE INSURANCE AFFORDED BY THE POLICIES DESCRIBED HEREIN IS SUBJECT TO ALL THE TERMS, EXCLUSIONS AND CONDITIONS OF SUCH POLICIES. LIMITS SHOWN MAY HAVE BEEN REDUCED BY PAID CLAIMS.

INSR LTR	TYPE OF INSURANCE	ADDL INSD	SUBR WVD	POLICY NUMBER	POLICY EFF (MM/DD/YYYY)	POLICY EXP (MM/DD/YYYY)	LIMITS	
A	<input checked="" type="checkbox"/> COMMERCIAL GENERAL LIABILITY <input type="checkbox"/> CLAIMS-MADE <input checked="" type="checkbox"/> OCCUR GEN'L AGGREGATE LIMIT APPLIES PER: <input checked="" type="checkbox"/> POLICY <input type="checkbox"/> PRO-JECT <input type="checkbox"/> LOC OTHER:	Y		CP3301626	04/15/2026	04/15/2027	EACH OCCURRENCE	\$ 1,000,000
							DAMAGE TO RENTED PREMISES (Ea occurrence)	\$ 500,000
							MED EXP (Any one person)	\$ 10,000
							PERSONAL & ADV INJURY	\$ 1,000,000
							GENERAL AGGREGATE	\$ 2,000,000
							PRODUCTS - COMP/OP AGG	\$ 2,000,000
								\$
	AUTOMOBILE LIABILITY <input type="checkbox"/> ANY AUTO <input type="checkbox"/> OWNED AUTOS ONLY <input type="checkbox"/> SCHEDULED AUTOS <input type="checkbox"/> HIRED AUTOS ONLY <input type="checkbox"/> NON-OWNED AUTOS ONLY						COMBINED SINGLE LIMIT (Ea accident)	\$
							BODILY INJURY (Per person)	\$
							BODILY INJURY (Per accident)	\$
							PROPERTY DAMAGE (Per accident)	\$
								\$
A	<input checked="" type="checkbox"/> UMBRELLA LIAB <input type="checkbox"/> OCCUR <input type="checkbox"/> EXCESS LIAB <input type="checkbox"/> CLAIMS-MADE <input type="checkbox"/> DED <input checked="" type="checkbox"/> RETENTION \$ 10000			CU3301635	04/15/2026	04/15/2027	EACH OCCURRENCE	\$ 1,000,000
							AGGREGATE	\$ 1,000,000
								\$
B	WORKERS COMPENSATION AND EMPLOYERS' LIABILITY ANY PROPRIETOR/PARTNER/EXECUTIVE OFFICER/MEMBER EXCLUDED? (Mandatory in NH) If yes, describe under DESCRIPTION OF OPERATIONS below	Y/N	N/A	83WECAC9T18	04/15/2026	04/15/2027	<input checked="" type="checkbox"/> PER STATUTE <input type="checkbox"/> OTHER E.L. EACH ACCIDENT	\$ 100,000
							E.L. DISEASE - EA EMPLOYEE	\$ 100,000
							E.L. DISEASE - POLICY LIMIT	\$ 500,000
A	Directors & Officers Liability			CP3301626	4/15/2026	4/15/2027	Per Occurrence	\$1,000,000
A	Liquor Liability			CP3301626	4/15/2026	4/15/2027	Per Occurrence	\$1,000,000

DESCRIPTION OF OPERATIONS / LOCATIONS / VEHICLES (ACORD 101, Additional Remarks Schedule, may be attached if more space is required)

City of Appleton as additional insured - when required by contract per form CGT1000

Commercial Umbrella follows forms of underlying policies.

CERTIFICATE HOLDER**CANCELLATION**

City of Appleton 100 N Appleton St Appleton, WI 54911	SHOULD ANY OF THE ABOVE DESCRIBED POLICIES BE CANCELLED BEFORE THE EXPIRATION DATE THEREOF, NOTICE WILL BE DELIVERED IN ACCORDANCE WITH THE POLICY PROVISIONS. AUTHORIZED REPRESENTATIVE 
---	--

© 1988-2015 ACORD CORPORATION. All rights reserved.