



MEMO

TO: Human Resources Committee
Municipal Services Committee

FROM: Paula Vandehey, Director of Public Works
Nathan Loper, Deputy Director of Operations

DATE: March 18, 2015

SUBJECT: Changes to the Department of Public Works Table of Organization - Operations

BACKGROUND

The Department of Public Works is proposing to modify our Table of Organization to address customer service, work assignments, supervision, safety, and succession planning objectives; while best meeting the City's Mission, Vision and Key Strategies. Copies of the existing and proposed Table of Organizations are attached.

Currently we have 11.5 FTE Laborers in Public Works - Operations, with approximately half of them spending the majority of their time performing work in a higher pay classification. Our laborers spend an average of 5,500 hours each year performing tasks above their pay grade. This is equivalent to 4 employees spending approximately 75% of their year working in a higher classification.

PROPOSED CHANGES

The Department of Public Works is proposing the following four (4) modifications to our Table of Organization:

1. Shift 3.0 FTE Laborers to 2.0 FTE Stormwater Operator I's and 1.0 FTE Street Operator I

The Stormwater Operator I positions will be responsible for the various maintenance projects associated with the City stormwater facilities, including excavating sediment, repairing outfalls and performing post-storm inspections to ensure water is flowing properly. As of 2015, we have 61 stormwater facilities to maintain. This number has increased by 9 since 2010 and is anticipated to increase by one additional facility each year over the next five years.

The Street Operator I position will be responsible for various street maintenance and repair tasks, including pothole patching, crack filling, asphalt paving and concrete repairs. Additional responsibilities include snow & ice removal, leaf collection and other various street projects.

Currently the Stormwater and Street Divisions are provided various personnel from the Laborer group; equivalent to at least 3.0 FTE annually performing these tasks. This poses a challenge since the Laborer positions typically tend to have a higher turnover rate and training efforts are not realized to their full potential. It takes significant time to train employees and provide them with the skills necessary to be efficient performing the many various stormwater facility and street maintenance tasks.

We believe that having 3 Operator I positions dedicated to this work will not only improve efficiency but also the quality of our streets, ponds and ravines.

2. Shift 1.0 FTE Laborer to 1.0 FTE Operations Crew Leader

This position will be a working lead position that will be assisting our Street Foreman with job planning and supervision of the 19 Street Division employees. This Division regularly has several projects going on at once, spread out across the City and it is challenging for one person to oversee all daily activities, even with a veteran supervisor in charge.

Having a crew leader in this group will help us improve customer service by responding to customer concerns in a more timely fashion. This will also help us be more efficient by having a crew leader on site to help plan ahead for projects, order materials and provide more oversight and direction of the crews.

Currently we do not have anyone ready to assume the Street Foreman responsibilities when this position comes vacant and the learning curve will be long due to the wide variety and number of projects this group is responsible for. By having a lead position in this group we will have someone much more prepared to be promoted to the Street Foreman position or at least be a great resource for the new Street Foreman in the future.

3. Shift 1.0 FTE Water Operator II to 1.0 FTE PM Shift Crew Leader

This position will be a working lead position that will work under the direction of the Water Foreman and will assist with job planning and supervision of the DPW night crews, including 2nd shift water construction, 2nd and 3rd shift CEA staff and the 3rd shift street sweeping/snow removal crews. Currently all of these employees work at night with little to no direct supervision.

Having a crew leader in this group will help us improve customer service by responding to customer concerns in a more timely fashion. This change will also help us to be more efficient by having a crew leader on site to help plan ahead for projects, call in and work with water main break repair crews and provide more oversight and direction of the night shift crews. Creating this position will allow us the opportunity to train and evaluate this employee for future vacant foreman positions as part of our succession planning initiative.

4. Shift 1.0 FTE Laborer to 1.0 FTE Arborist

This position will be responsible for various tree maintenance and removal tasks, including tree climbing, pruning, planting and removals. Additional responsibilities include the safe and effective operation of chainsaws, large lifts and log loading equipment.

Currently the Forestry group is supplemented with various personnel from the Laborer group; equivalent to at least 1.0 FTE being assigned annually to Forestry tasks. This poses a challenge since the Laborer positions typically tend to have a higher turnover rate and training efforts are not realized to their full potential. It takes significant time to train employees and provide them with the skills necessary to be efficient performing the many various tree maintenance tasks.

We believe that having an additional arborist position dedicated to this work will improve efficiency and safety. This is especially important with the increased forestry workload as a result of the emerald ash borer being confirmed in Appleton as well as the increasing ratio of trees to arborists. In 2010 the tree to arborist ratio was 3975 to 1 with a 7.5 year pruning cycle. In 2014 the tree to arborist ratio was 4704 to 1 with an 8.5 year pruning cycle, compared to an industry standard 5 year pruning cycle.

BENEFITS OF PROPOSED CHANGES

The proposed modifications to our Table of Organization described above shifts 5.0 FTE Laborer and 1.0 FTE Water Operator II to 2.0 FTE Crew Leader, 3.0 FTE Operator I and 1.0 FTE Arborist positions. **The overall table of organization would have the same number of FTE's and all existing employees would remain employed in Public Works.**

We feel that these changes are consistent with the City's Strategic Plan as follows:

- **Key Strategy #1** - Communicate City Priorities and allocate resources accordingly. The priorities of the City are constantly shifting as new challenges, regulations, etc. come to fruition. A relevant example is with the discovery of Emerald Ash Borer in Appleton. We have been proactively addressing this anticipated challenge for years, but will now have to put additional resources into mitigating the detrimental effects of this disease to our urban forest. Another example is with our ever growing inventory of stormwater facilities to meet our WisDNR Permit. As the inventory of ponds, streams and ravines continues to grow, so must the resources we allocate to maintaining these valuable community assets.
- **Key Strategy #4** - Attract and retain an inspired, engaged workforce. Today's generation of employees are looking for growth opportunities and want to feel a sense of pride and accomplishment in the work they do on a day-to-day basis. The proposed table of organization creates new lead positions that provide career growth opportunities for employees that may wish to be Foremen in the future. It also creates two positions dedicated to stormwater for employees that are interested in "owning" the care of these multi-million dollar facilities.

In addition to meeting the Key Strategies, the proposed changes provide the following overall benefits to the City:

- Improved Customer Service - A recurring theme we heard in our recent DPW Customer Survey was the need to improve communication with neighborhoods during DPW maintenance projects. The proposed Lead Positions would include the responsibility of neighborhood notification of projects such as our Concrete Pavement Rehabilitation Program and Hydrant Painting Program.
- Increased Supervision - An on-going challenge has been providing supervision during our PM shift when water staff, street sweepers, and CEA mechanics routinely work. Having the presence of this Lead Position will improve oversight/accountability of both staff and projects.
- Improved Safety - Having the Lead Positions will improve safety through quicker dispatching of crews during the PM shift and enhanced project safety (such as improved barricading) with the additional supervisory presence in the field.
- Meets Succession Planning Objectives – With our continued aging workforce, we need to prepare for seamless transitions as key positions are vacated through retirements. Our Succession Plan includes retaining our most gifted employees to help our Department successfully meet our Mission of “Providing essential services in an exceptional manner.”

SUMMARY OF FINANCIAL IMPLICATIONS

The anticipated financial impacts for the proposed changes are described below.

1. Stormwater Operator I (2.0 FTE) and Street Operator I (1.0 FTE) – We anticipate these changes to equate to a total salary impact of approximately \$6,000 which would be off-set by holding the Laborer position that is currently vacant for the remainder of the year.
2. Operations Crew Leader (1.0 FTE) – We anticipate this change to equate to a total salary impact of approximately \$4,800 which would be off-set by holding the Laborer Position that is currently vacant for the remainder of the year.
3. PM Shift Crew Leader (1.0 FTE) – We anticipate this change to equate to a total salary impact of approximately \$2,300 which would be off-set from our current Water Operator II vacancy.
4. Arborist (1.0 FTE) – We anticipate this change to equate to the elimination of the vacant Laborer position and hiring of a new Arborist for a total salary impact of approximately \$12,100 per year, and if approved, will be included in our 2016 General Fund Budget.

In order to best meet the City’s Strategic Plan, improve customer service, increase supervision, improve safety and meet our succession planning objectives, we recommend that the Public Works Table of Organization be modified to shift 5.0 FTE Laborer positions and 1.0 FTE Water Operator II position to 3.0 FTE Operator I, 2.0 FTE Crew Leader and 1.0 FTE Arborist positions.

Attachment

Operational Detail

1.0 - DPW Deputy Director
Operations

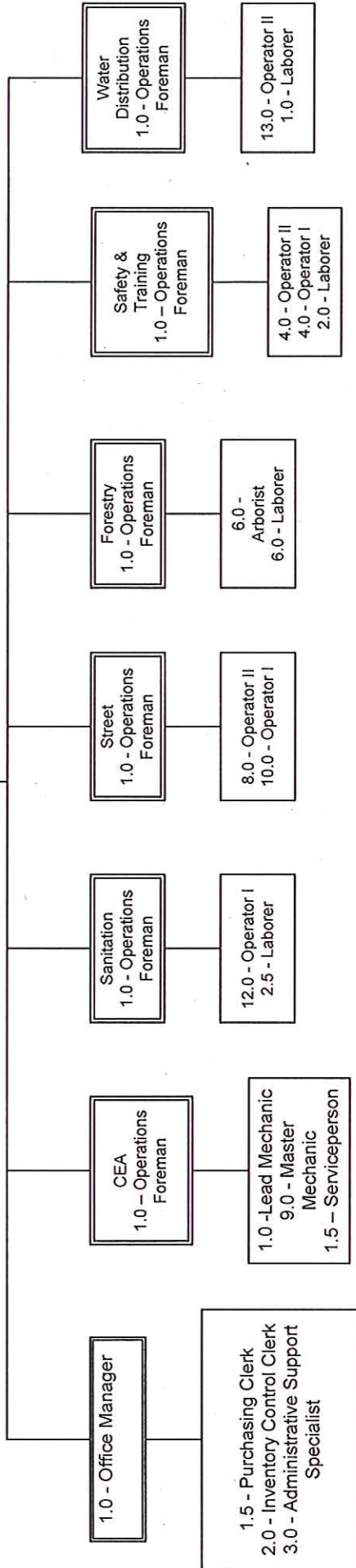

1/1/2015

Operational Detail

1.0 - DPW Deputy Director
Operations

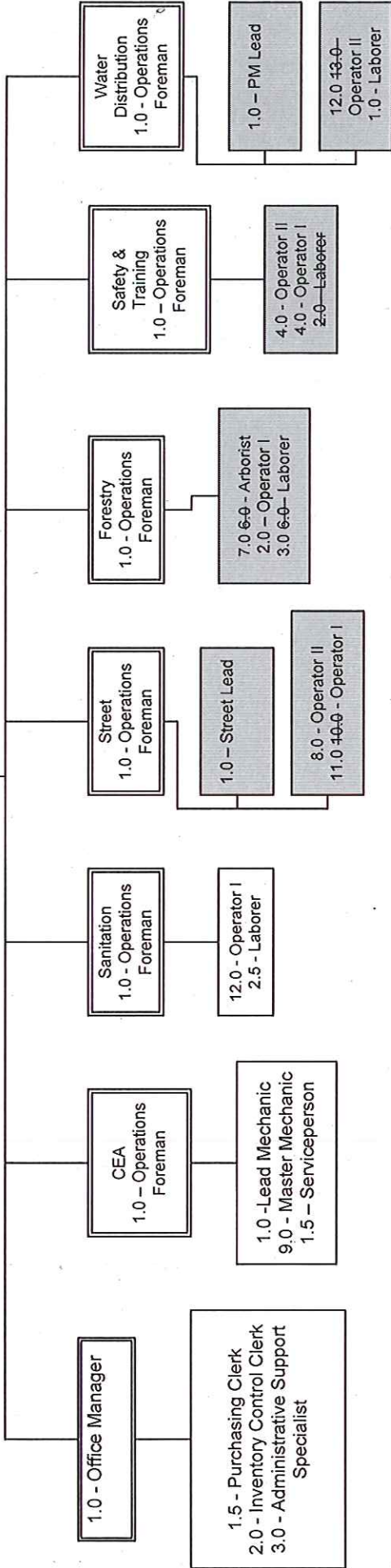

Proposed Draft 3-23-15